

045AT20 PISTON ACCUMULATORS

Model Number	Gas Capacity		Fluid Capacity		Dry Weight		Dimension A		Dimension B	
	In. ³	Cm. ³	Gallon	Liters	Lbs.	Kg.	Inch	mm	Inch	mm
045AT20-4NA1D	128	2,094	.5	2	27	12	15-5/8	397	14-3/8	365
045AT20-8NA1D	243	3,981	1	4	36	16	24-1/4	616	23	584
045AT20-16NA1D	475	7,780	2	8	53	24	41-5/8	1,057	40-3/8	1,026
045AT20-24NA1D	705	11,552	3	12	69	31	58-7/8	1,495	57-5/8	1,464

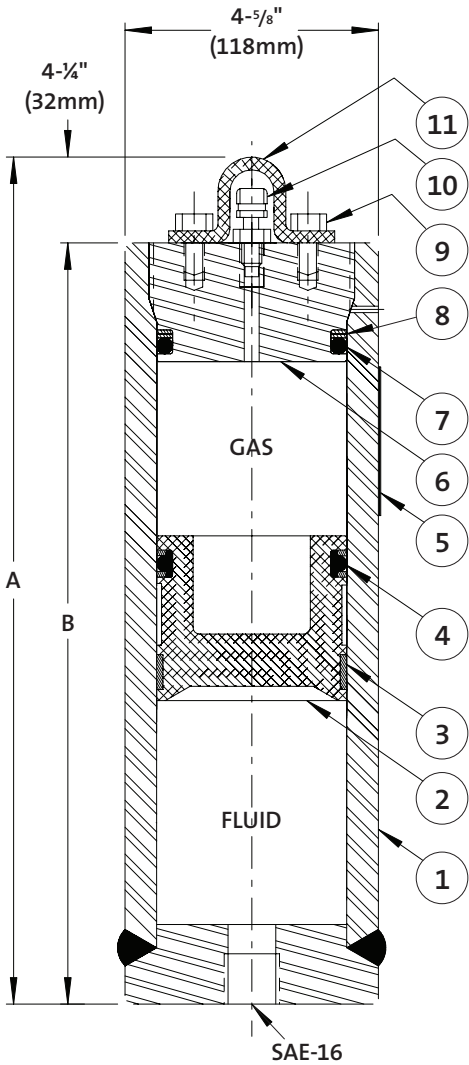

Maximum working pressure 2,000 psi (138 bar)
 Maximum proof pressure 3,000 psi (207 bar)
 Minimum burst pressure 8,000 psi (552 bar)

Operating temperature (BUNA/Nitrile)
 -20° to +200°F (-28° to 93°C)

TOBUL ACCUMULATOR INCORPORATED
www.fst.com

FREUDENBERG
 SEALING TECHNOLOGIES

Item Number	Part Number	Description	Number Required
X	HFV33MA8-D	Head, Fluid, SAE-16, Welded to Cylinder	1
1	C37TA33-109.5AT	Cylinder, 045A20-4, .5 Gallon, 2 Liter	1
	C37TA33-178.5AT	Cylinder, 045A20-8, 1 Gallon, 4 Liter	
	C37TA33-317.5AT	Cylinder, 045A20-16, 2 Gallon, 8 Liter	
	C37TA33-455.5AT	Cylinder, 045A20-24, 3 Gallon, 12 Liter	
2	P33MH21T	Piston, Aluminum	1
3	SW.6T-8	Wearband, Piston, TEFLON	1
4	ST3N60Y	Seal, Piston, "T" Seal Assembly, BUNA/NYLON	1
5	NP-300	Nameplate	1
6	HG33MA16-1	HEAD, GAS, 1/2-20	1
7	SO3N60	Seal, O-Ring, Head, BUNA-N	1
8	SB3T60	Seal, Backup, TEFLON	1
9	B-.37CB16S6-B	Bolt, Carbon Steel, 3/8-16 x 3/4	2
10	3A-283	SS Valve, Gas, 3K, 1/2-20 UNF-3A	1
11	3A-754D	Guard, Valve, Aluminum	1

Optional porting/mounting/piston seal configurations available on request

Complete seal kits

New Part Number	Type	Old Part Number
SK045AT20-NT	BUNA-N	4.5A20-G40T-NST
SK045AT20-VT	FKM (VITON®)	4.5A20-G40T-ETT
SK045AT20-ET	EPR	4.5A20-G40T-HTT

160A20 PISTON ACCUMULATORS

Model Number	Gas Capacity		Fluid Capacity		Dry Weight		Dimension A	
	In. ³	Cm. ³	Gallon	Liters	Lbs.	Kg.	Inch	mm
160A20-320AG1K	9530	156,175	40	152	1411	640	76-7/8	1953
160A20-480AG1K	14,149	231,853	60	227	1811	821	106-7/8	2715
160A20-640AG1K	18,767	307,531	80	303	2211	1003	136-7/8	3477
160A20-800AG1K	23,385	383,209	100	379	2611	1184	166-7/8	4239
160A20-1200AG1K	34,930	572,403	150	568	3611	1638	241-7/8	6144

Tobul 160A20 Series Accumulators meet the requirements of ASME Code certification for pressure vessels

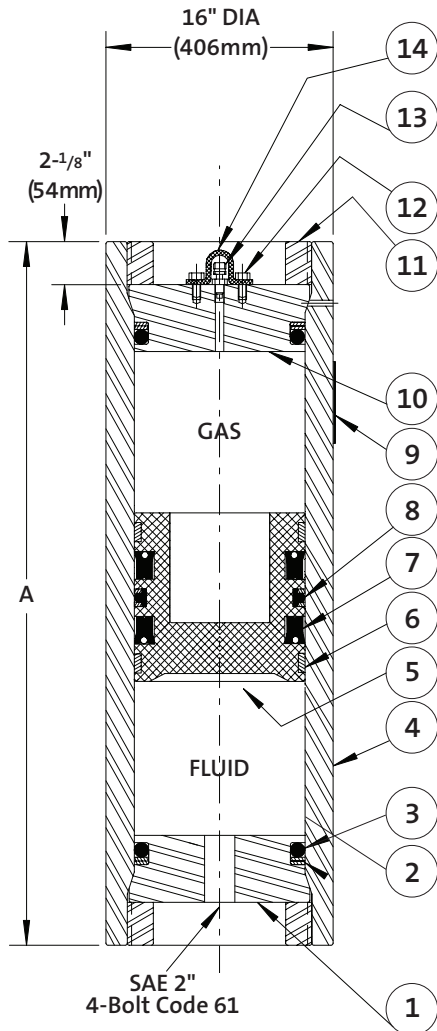

Maximum working pressure 2,000 psi (138 bar)
 Maximum proof pressure 3,000 psi (207 bar)
 Minimum burst pressure 8,000 psi (552 bar)

Operating temperature (BUNA/Nitrile)
 -20° to +200°F (-28° to 93°C)

TOBUL ACCUMULATOR INCORPORATED
www.fst.com

FREUDENBERG
 SEALING TECHNOLOGIES

Item Number	Part Number	Description	Number Required
1	HG112WCB22-K	Head, Fluid, 2" SAE 4 BLT Code 61	1
2	SB4T216	Seal, BACKUP, TEFLON	2
3	SO4N216	Seal, O-Ring, Head, BUNA-N	2
4	C128TD112-615	Cylinder, 160A20-320, 40 Gallon, 151 LITER	1
	C128TD112-855	Cylinder, 160A20-480, 60 Gallon, 227 LITER	
	C128TD112-1095	Cylinder, 160A20-640, 80 Gallon, 303 LITER	
	C128TD112-1335	Cylinder, 160A20-800, 100 Gallon, 379 LITER	
	C128TD112-1935	Cylinder, 160A20-1200, 150 Gallon, 568 LITER	
5	P112WH56P	Piston, SD, Aluminum	1
6	SW2BT-12	Seal, Bearing, BFT	2
7	SP6M212N-10	Seal, Piston, SEVERE DUTY U-THANE/BUNA	2
8	ST4N212Y	Seal, Piston, "T" SEAL ASSEMBLY, BUNA/NYLON	1
9	NP-300	Nameplate	1
10	HG112WC22-1	HEAD, GAS, 1/2-20	1
11	RR112WC90-17	Ring, Retaining	2
12	B-.37CB16S6	Bolt, Carbon Steel, 3/8-16 x 1/4	2
13	3A-283	SS Valve, 3K, 1/2-20 UNF-3A	1
14	3A-754D	Guard, Valve, Aluminum	1

Optional porting/mounting/piston seal configurations available on request

Complete seal kits

New Part Number	Type	Old Part Number
SK160A20-AP	BUNA-N Severe Duty	16A20-G40P-NST
SK160A20-GP	FKM (VITON®) Severe Duty	16A20-G40P-ETT

Specify seal material by selecting appropriate material code –
 "N"= Buna-N; "B"= Butyl; "E"= EPR; "V"= FKM (Viton®)